

La Fleur

(with Dishcharge pump)

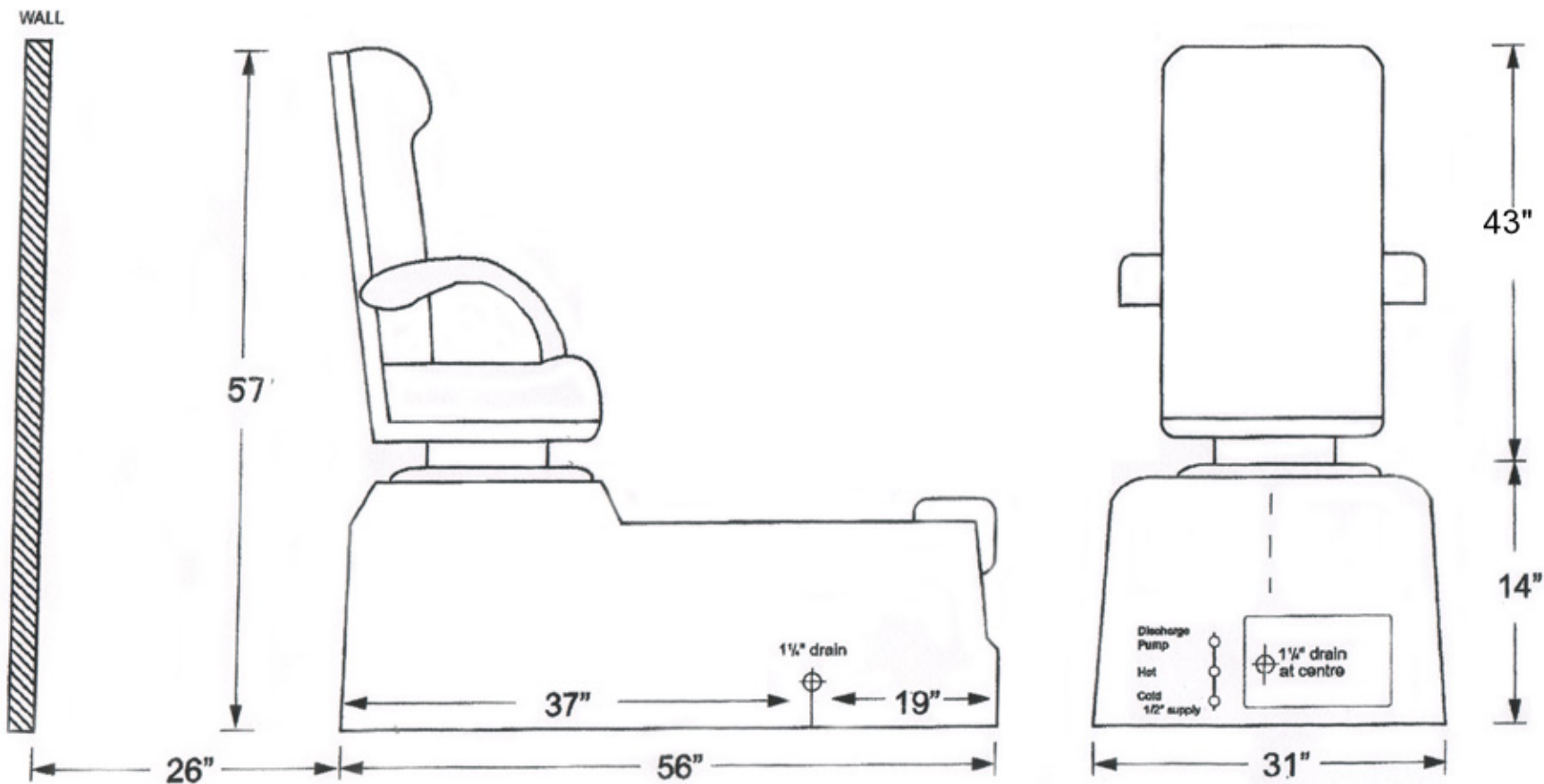

La Fleur

(without Dishcharge pump)

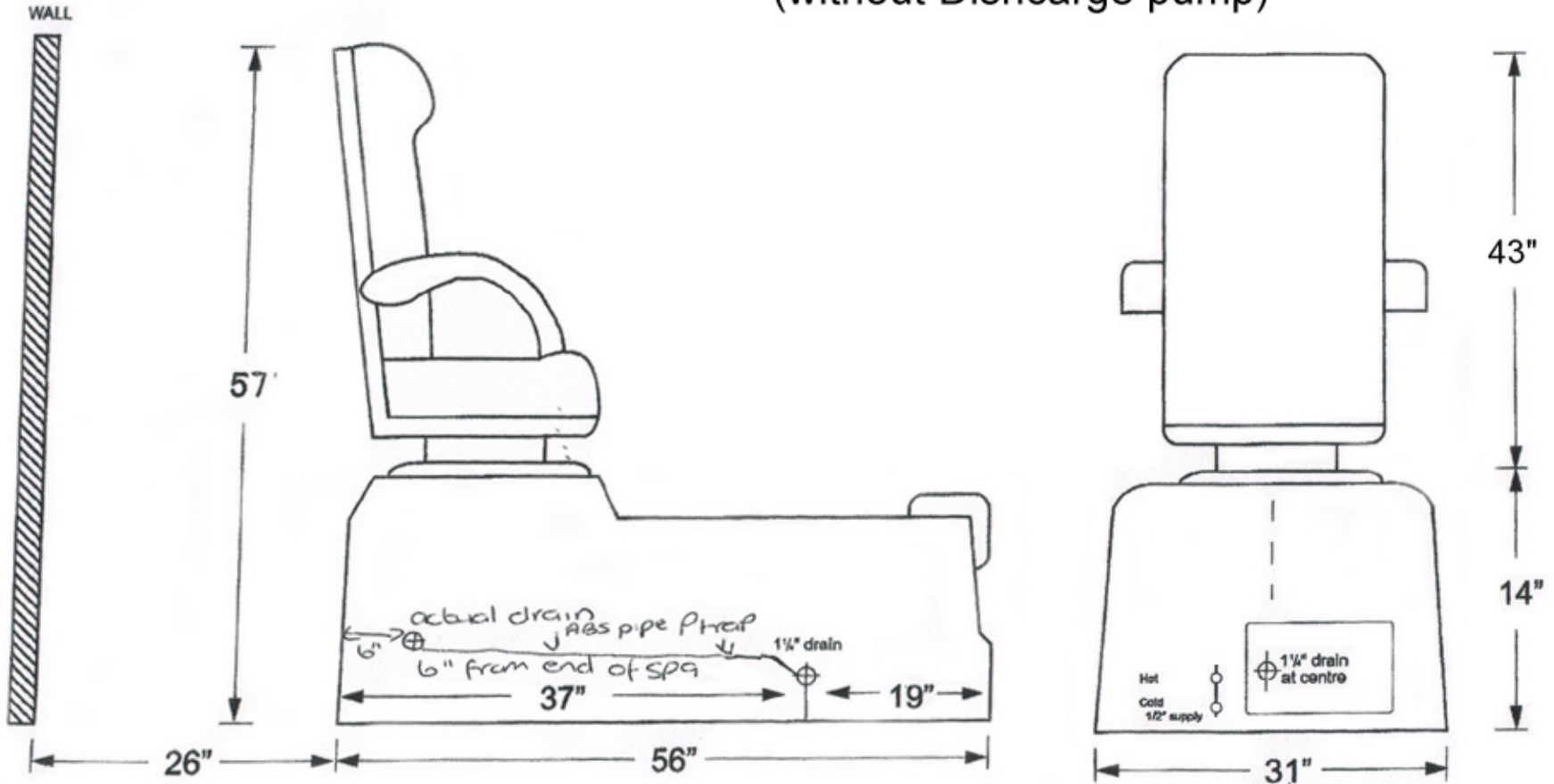

SPECIFICATIONS

Weight	290 lbs. (132kg) - Shipping weight 340lbs. (154 kg.)
Bowl Capacity	4 US Gal (15L)
Water Source	Must meet local plumbing codes. V200275 backflow preventer factory installed. Normal water pressure of 30 to 120 PSI required.
Drain Source	1 1/4 drain. Must meet local plumbing codes using drain pipe and appropriate traps. Factory installed discharge pump (optional) 1/2 outlet
Electrical	Whirlpool pump: 1/2 HP 115V 5.7 AMP 60hz 12V DC Discharge pump: 110V 5.5 AMP 60hz 12V Recommended 20 AMP service / Ground fault interrupter required.
Base Material	Premium quality genuine lucite cast acrylic reinforced with fibreglass and resin gel
Chair Material	Premium soil and stain resistant ultra leatherette - Protective finish manufactured to provide protection in medical and health care environments
Warranty	ONE YEAR WARRANTY on Spa Shells, Massage Unit, Pump and Motor